



S SERIES SCREENING

With the largest screening areas in their class, McCloskey's screeners are designed to give customers high output and durability even in the most demanding conditions, and deliver high production across industries.

With class-leading features like the aggressive High Energy Screenbox and ease of operation, the S Series screeners are available in dual power for both double & triple deck models.

Dual power boosts fuel efficiency, reducing costs,

and is perfect where environmental, legislative, or noise constraints are present. All S Series screeners offer fast screen changes & optimal screen coverage.

Triple Decks have the highest combined true screening area across three decks and paired with their high energy screening action the McCloskey S Series models are the superior choice in material screening. Easy to maintain, the screeners feature enhanced accessibility for screen changes with an easy-to-use wedge system for faster screen changes.

HOPPER

Grid opening allows the use of larger loading shovels and is easily operated with remote control.

PRODUCT CONVEYORS

Four product capability with integrated and hydraulic stoppiling conveyors.



TRIPLE DECK

Also offered as a triple deck for the highest combined true screening area across three decks.

LINKAGE SYSTEM

Hydraulic screenbox linkage system allows greater accessibility for screen change and enable optimum screenbox coverage at varying angles.

S SERIES SCREENERS

SCREENBOX

Adjustable screenbox angles allow adaptability to a wide range of material applications. User friendly wedge system ensures faster screen changes.

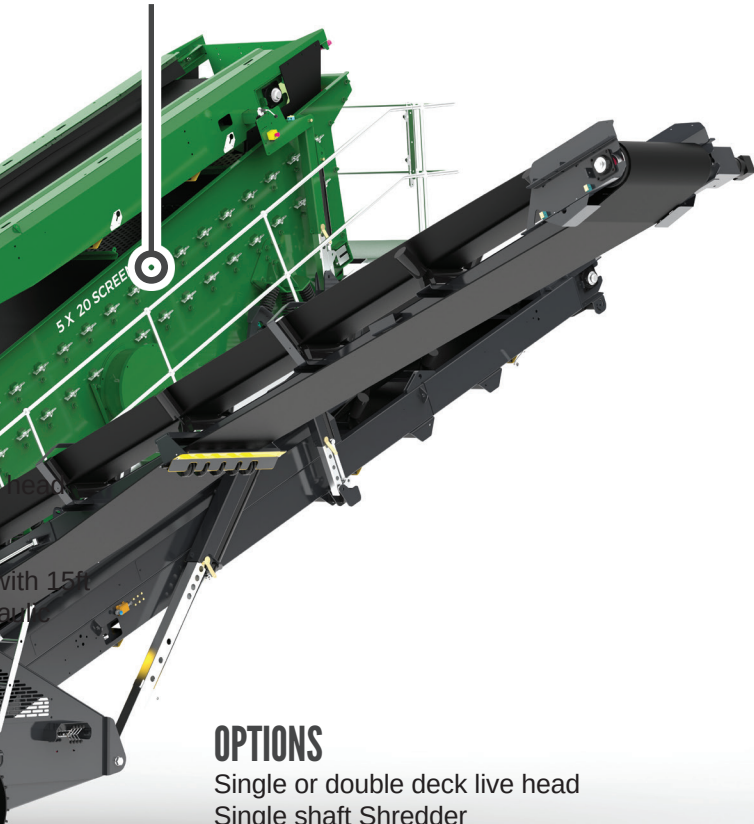

OPTIONS

Single or double deck live head
Single shaft Shredder
12ft Hopper
Crusher chute (available with 15ft hopper only)
Auxiliary hydraulic circuit
Dual diesel/electric power

FEATURES

- Screenbox - High Energy screenbox provides high production screening with no “dead” area
- Linkage System - Hydraulic Screenbox linkage system, allows great accessibility for screen change and enables optimum screen coverage at varying screenbox angles.
- Wedge System - User friendly wedge system ensures faster screen changes.
- Hopper - Wide grid opening allows the use of larger loading shovels.
- Main Conveyor – feed conveyor enables high capacity screening
- Remote control tipping grid
- Fast on-site setup time – 15 minutes typically

MORE OPTIONS

McCloskey screeners are ready to get to work in dual power and electric formats. Dual power boosts your operational fuel efficiency, reducing costs, and full electric models are perfect where environmental, legislative, or noise constraints are a consideration.



DUAL POWER

S80 SCREENER

Engine	98 kW (130 HP)
Screenbox Top Deck	3050mm x 1370mm (10' x 4.5')
Screenbox Bottom Deck	2440mm x 1370mm (8' x 4.5')
Belt Width Main Conveyor	900mm (36')
Stockpile Height Tail Conveyor	3790mm (12'-5")
Stockpile Height Fine Side Conveyor	4110mm (13'-6") - Product

S110 SCREENER

Engine	100 kW (134 HP)
Screenbox Top Deck	3660mm x 1525mm (12' x 5')
Screenbox Bottom Deck	3050mm x 1524mm (10' x 5')
Belt Width Main Conveyor	1050mm (42")
Stockpile Height Tail Conveyor	4.2m (13' 3/4")
Stockpile Height Fine Side Conveyor	4.6m (15' 2")

S250 SCREENER

Engine	165 kW (225 Hp)
Screenbox Top Deck	6710mm x 1830mm (22' x 6')
Screenbox Bottom Deck	6100mm x 1830mm (20' x 5')
Belt Width Main Conveyor	1200mm (48")
Stockpile Height Tail Conveyor	4992mm (16' - 4.5")
Stockpile Height Fine Side Conveyor	5398mm (17' - 8.5")

S130 SCREENER

Engine	74.5 kW (100 Hp)
Screenbox Top Deck	4270mm x 1524mm (14' x 5')
Screenbox Bottom Deck	3660mm) x 1524mm (12' x 5')
Belt Width Main Conveyor	1050mm (42")
Stockpile Height Tail Conveyor	3871mm (12' - 8") -
Stockpile Height Fine	4600mm (15'-1")

S190 SCREENER

Engine	98 kW (130 HP)
Screenbox Top Deck	6100mm x 1524mm (20' x 5')
Screenbox Bottom Deck	5490mm x 1524mm (18' x 5')
Belt Width Main Conveyor	1050mm (42")
Stockpile Height Tail Conveyor	4638mm (15' - 3")
Stockpile Height Fine Side Conveyor	5100mm (16' - 9")

